

# Regional Water Resource Agency

## Request for Proposal

Bid Name	RWRA Three Duplex Pump Control Panels
Bid Number	2025-29
Bid Opening Date and Time	Friday, February 28, 2025
Bid Type	Non-Public Opening

TO ALL PROSPECTIVE BIDDERS:

You are hereby invited to submit a bid for the item(s) specified within.

All Bidders are responsible for reading and complying with the attached specifications.

The Bidder certifies that all exceptions and conflicts to these contract documents have been detailed on the "Bidder's Exceptions, Conflicts and Clarifications" on page 3 of this document.

Pages contained within this bid package shall not be electronically altered. Failure to comply with these instructions may result in the rejection of the Bidder's proposal.

**BIDDER'S INFORMATION:**

Company's Legal Name: \_\_\_\_\_

Address: \_\_\_\_\_

City, State & Zip Code: \_\_\_\_\_

Telephone Number: \_\_\_\_\_

Fax Number: \_\_\_\_\_

Authorized Email Address: \_\_\_\_\_

Authorized Signature: \_\_\_\_\_

Printed Name: \_\_\_\_\_

**Bidder's Exceptions, Conflicts and Clarifications**

**The Bidder acknowledges the following Addenda issued prior to Bid Opening Date:**

---

If there are no exceptions taken, please CHECK and INITIAL the line below.

NO EXCEPTIONS: \_\_\_\_\_

If exceptions are taken to the bid, please complete the following page, identifying each exception.

The Bidder certifies that he agrees to all provisions of the bid documents, unless exceptions are specifically and clearly listed on the attached pages of this document and identified as exceptions.

Exceptions to the bid specifications should be noted by number on the appropriate specification sheet and those exceptions are to be explained in the attached pages.

Any and all exceptions to the bid proposal must be spelled out in writing on the attached pages; this includes any exception in the Bidder's "Terms and Conditions". The Bidder's printed "Terms and Conditions" are not considered specific exceptions.

Exceptions NOT listed on the attached RWRA Document will not be taken into consideration; this includes the Bidder's attachments, documents, and/or terms and conditions.

Any reference to "See attached exceptions" will not be considered, EXCEPTIONS must be listed on the attached RWRA document.

Copies can be made of the RWRA Exceptions document if additional space is needed.

Bidder acknowledges that ALL exceptions have been included on the "RWRA Specifications" page(s).

Date: \_\_\_\_\_

Company Name: \_\_\_\_\_

Company Representative: \_\_\_\_\_

**Bidder's Exceptions, Conflicts and Clarifications**

Any reference to "See attached exceptions" will not be considered, EXCEPTIONS must be listed on the RWRA provided document. Copies of this page may be made if additional space is needed.

**Vendor's Statements Pursuant to KRS 45A.343 and KRS 45A.395**

KRS 45A.343:  
The undersigned, as a duly authorized officer of \_\_\_\_\_ pursuant to KRS 45A.343 states:

1. To the best of my knowledge, information and belief, \_\_\_\_\_ has not been finally determined to have violated any of the provisions of KRS Chapters 136, 139, 141, 337, 338, 341 or 342 that apply to it within the five year period preceding this statement.
2. \_\_\_\_\_ acknowledges that it will be required to be in compliance with those provisions of KRS Chapters 136, 139, 141, 337, 338, 341 and 342 that apply to it for the duration of the contract to be entered into with Regional Water Resource Agency.
3. \_\_\_\_\_ acknowledges that if it fails to reveal any final determination of violation of KRS Chapters 136, 139, 141, 337, 338, 341 or 342 or to comply with the applicable provisions of those statutes for the duration of the aforesaid Contract, such shall be grounds for Regional Water Resource Agency to:
  - a. Cancel its contract with \_\_\_\_\_, and
  - b. Disqualify \_\_\_\_\_ from eligibility for future contracts awarded by Regional Water Resource Agency for a period of two years.

KRS 45A.395:  
The provisions of KRS45A.395 require that any bidder or offeror submit a sworn statement in conformity with such statute as a prerequisite to a determination that such bidder or offeror is a responsible bidder. The undersigned, individually and as the \_\_\_\_\_ (title) of \_\_\_\_\_ (bidder or offeror) states under penalty perjury that neither he (she), not, to the best of his (her) knowledge, anyone acting on behalf of Bidder or Offeror, has knowingly violated any provision of the campaign finance laws of the Commonwealth of Kentucky and that the award of a contract to the Bidder or Offeror will not violate any provision of the campaign finance laws of the Commonwealth. "Knowingly" means, with respect to conduct or to a circumstance described by a statute defining an offense, that a person is aware or should have been aware that his conduct is of that nature or that his conduct is of that nature or that circumstance exists.

\_\_\_\_\_  
(Company Name)

\_\_\_\_\_  
(Signature) (Title)

\_\_\_\_\_  
(Typed or printed name)

This the \_\_\_\_\_ day of \_\_\_\_\_, 20\_\_\_\_\_.

**Prohibition of Conflicts of Interest, Gratuities, Kickbacks and Use of Confidential Information**

Kentucky law prohibits conflicts of interest, gratuities, kickbacks and the use of confidential information with regard to any public contract or a solicitation or proposal therefore. The prohibitions are set for in KRS 45A.455 which provides:

1. It shall be a breach of ethical standards for any employee with procurement authority to participate directly in any proceeding or application; request for ruling or other determination; claim or controversy; or other particular matter pertaining to any contract or subcontract, and any solicitation or proposal therefore, in which to his knowledge:
  - a. He, or any other member of his immediate family has a financial interest therein; or
  - b. A business or organization in which he or any member of his immediate family has a financial interest as an officer, director, trustee, partner, or employee, is a party; or
  - c. Any other person, business or organization with whom he or any member of his immediate family is negotiating or has an arrangement concerning prospective employment is a party. Direct or indirect participation shall include but not be limited to involvement through decision, approval, disapproval, recommendation, preparation of any part of a purchase request, influencing the content of any specification or purchase standard, rendering of advice, investigation, auditing or in any other advisory capacity.
2. It shall be a breach of ethical standards for any person to offer, give or agree to give any employee or former employee, or for any employee or former employee to solicit, demand, accept or agree to accept from another person, a gratuity or an offer of employment, in connection with any decision, approval or disapproval, recommendation, preparation of any part of a a purchase request, influencing the content of any specification or purchase standard, rendering of advice, investigation, auditing, or in any other advisory capacity in any proceeding or application, request for ruling or other determination, claim or controversy, or other particular matter, pertaining to any contract or subcontract and any solicitation or proposal therefore.
3. It is a breach of ethical standards for any payment, gratuity, or offer of employment to be made by or on behalf of a subcontractor under a contract to the prime contractor or higher tier subcontractor or any person associated therewith, as an inducement for the award of a subcontract or order.
4. The prohibition of conflicts of interest, gratuities and kickbacks shall be conspicuously set forth in every local public agency's written contract and solicitation therefore.
5. It shall be a breach of ethical standards for any public employee or former employee knowingly to use confidential information for his actual or anticipated personal gain, or the actual or anticipated personal gain of any other person (Enact. Acts 1978, ch. 100, S 92, effective January 1, 1980; ch. 250, S 16, effective April 9, 1980.)

Violation of the statute may result in a fine and/or imprisonment under the provisions of KRS 5A.990.

**INDEMNITY AGREEMENT**

\_\_\_\_\_ (the "Contractor") desires to provide labor and materials to the Regional Water Resource Agency ("RWRA"); RWRA is willing to allow the Contractor to provide labor and materials under the following conditions.

The parties therefore agree as follows:

1. The Contractor shall assume all responsibility and liability for the negligent acts or omissions of its agents, servants, or employees. The Contractor shall be responsible for its employees and shall exercise all dominion, control, and authority over the means and methods used by its employees to perform any work for RWRA or while on RWRA property.
2. The Contractor shall comply with all federal, state, and local occupational safety and health laws and regulations, and local, state, and federal laws and regulations for "Maintenance and Control of Traffic During Construction".
3. To the fullest extent permitted by law, Contractor shall indemnify RWRA, its officers, directors, agents, and employees from all claims for bodily injury and property damage, including reasonable attorneys' fees, costs, and expenses, that may arise from the performance of Contractor's work, but only to the extent caused by the acts or omissions of the Contractor or anyone employed directly or indirectly by the Contractor or by anyone for whose acts any of them may be liable.

The effective date shall be considered the latter of the two dates as listed.

**Contractor:** \_\_\_\_\_

**Owner: RWRA**

**Print Name:** \_\_\_\_\_

**Print Name:** \_\_\_\_\_

**Signed By:** \_\_\_\_\_

**Signed By:** \_\_\_\_\_

**Date:** \_\_\_\_\_

**Date:** \_\_\_\_\_

**SUBMITTAL CHECKLIST**

The following completed documents should be included in your submitted proposal (originals and one copy). Indicate on the first page of each set of documents 'ORIGINAL' or "COPY". The original bid documents and the copies shall be submitted in one sealed envelope.

	INVITATION FOR PROPOSAL PAGE WITH BIDDER'S SIGNATURES AND CONTACT INFORMATION (first page)
	ADDENDA ACKNOWLEDGEMENT (IF APPLICABLE) (pg. 2)
	EXCEPTIONS, CONFLICTS & CLARIFICATIONS FORM(S) (page 3)
	VENDOR'S STATEMENTS PURSUANT TO KRS 45A.343 AND KRS 45A.395. (page 4)
	PROHIBITION OF CONFLICTS OF INTEREST, GRATUITIES, KICKBACKS AND USE OF CONFIDENTIAL INFORMATION (page 5)
	INDEMNITY AGREEMENT (page 6)
	PROPOSAL QUOTATION SHEET (pg. 20)
	BIDDER'S W-9 FORM

## Instructions to Bidders

### SCOPE

The Regional Water Resource Agency (RWRA) is seeking proposals for (3) Arc-Flash Rated Duplex Pump Control Panels for: Lamplite Pump Station, Wrights Acres Pumps Station and Eastview Pump Station. This Request for Proposal (RFP) contains specific information about the scope of services, submission requirements and selection procedures.

### Due Date and Time

All bids must be submitted as described within this document to **1722 Pleasant Valley Road, Owensboro, KY 42303, Attn: Tonya Smith, Purchasing Manager, no later than 2:00 pm local prevailing time on Friday February 28, 2025, at this time all bids received will be opened but not publicly read. Any bids received after the due date and time will be returned unopened.**

Requests for additional information or clarifications must be made in writing and received by the Purchasing and Administration Manager. The request must contain the RFP number and title, Proposer's name, name of Proposer's contact person, address, phone number and email.

RWRA will issue responses to inquiries, and any other corrections or amendments it deems necessary, in written addenda issued prior to the Proposal Submission Date. Proposers should not rely on any representations, statements or explanations other than those made in this RFP, or in any written addendum to this RFP. Where there appears to be conflict between the RFP and any addenda issued, the last addendum issued shall prevail. Any request for additional information or clarification must be received in writing no later than 2:00 p.m. (CST), February 25, 2025. Please note that all questions shall be addressed in a subsequent addendum only AFTER the deadline for requests for additional information/clarification.

### QUESTIONS:

For all questions (RFI) regarding these bid documents contact

Tonya Smith  
Purchasing and Administration Manager  
270-687-8440  
[bids@rwra.org](mailto:bids@rwra.org) or [Tonya.Smith@rwra.org](mailto:Tonya.Smith@rwra.org)

Proposer agrees that it is responsible for clarifying any ambiguity, conflict, discrepancy, omission, or other error found in the RFP prior to the Proposer submitting its Bid or the right to clarify same shall be waived.

### SUBMIT SEALED BID TO:

TONYA SMITH  
Regional Water Resource Agency  
1722 Pleasant Valley  
Owensboro, KY 42303



**ALL BIDS MUST BE RECEIVED BY 2pm on Friday February 28, 2025, if received after this time the bid will be returned to Bidder unopened.**

## General Compliance

Please read these instructions carefully.

### Bid Submission

All pages of the bid shall be signed in ink on the designated signature lines. Typed quotation sheets are preferred; however, if hand written, the sheets must be legible and in ink. Any pricing information that is illegible may result in the rejection of the bid.

Quotations must be made on the form provided. An accompanying letter of explanation is acceptable if bidder deems it necessary, but only quotes made on the provided forms will be evaluated.

In case of a discrepancy in the extension of a unit price, the unit price shall govern over the total price.

Bidders must provide manufacturer's product literature if available and appropriate with the bid submission. Price quotes shall remain firm and open to acceptance by the RWRA for a minimum period of sixty (60) days after bid opening.

The signed completed original bid package and copy must be sealed in an envelope with the bidder's name, the bid number, and the bid opening date clearly marked on the outside of the envelope. **The bids shall be addressed and delivered to Regional Water Resource Agency, Attn: Tonya Smith, Purchasing Manager, David Hawes East Treatment Plant, 1722 Pleasant Valley Road, Owensboro, KY 42303.**

### Bid Copies

When submitting bids, you must include the original signed bid, along with one (1) copy of the entire bid. Indicate on the first page of the bid "ORIGINAL" or "COPY". The original bid and all copies shall be submitted in one envelope.

### Taxes

All prices shall be quoted exclusive of any taxes. RWRA is exempt of all Federal excise, transportation and/or Kentucky sales tax. Any items supplied directly to RWRA from a supplier/manufacturer are exempt from sales tax. Any items purchased by a contractor that will be used in the fulfillment of a contract are not exempt from sales tax.

### Bidder's Qualifications

Bidders must demonstrate to the satisfaction of RWRA that he has adequate equipment, personnel, experience and understanding of the specifications to be performed under the contract.

If and wherever in the specifications brand names, makes, models, names of any manufacturer, trade names, or Bidder/Proposer catalog numbers are specified, it is for the purpose of establishing the type, function, minimum standard of design, efficiency, grade, or quality of goods only. When RWRA does not wish to rule out other competitors' brands or makes, the phrase "OR EQUAL" is added. When bidding/proposing an approved equal, Bidder/Proposer shall submit, with their response, complete sets of necessary data (factory information sheets, specifications, brochures, etc.) in order for RWRA to evaluate and determine the equality of the item(s) bid/proposed. RWRA shall be the sole judge of equality and its decision shall be final. Unless otherwise specified, evidence in the form of samples may be requested if the proposed brand is other than specified by RWRA. Such samples are to be furnished after Formal Solicitation opening/closing only upon request of RWRA. If samples should be requested, such samples must be received by RWRA no later than seven (7) calendar days after a formal request is made.

No contract will be awarded to any bidder who, in the opinion of RWRA, is not qualified to perform satisfactorily due to a previously unfavorable performance, reputation or lack of experience, capital, organization, equipment, and/or personnel to conduct and complete the services in accordance with the terms and conditions of the contract.

### Method of Procurement

Competitive Sealed Bidding (KRS 45A.365) will be the method of procurement for the purchase of the item(s) listed herein.

### Bid Award

This bid will be evaluated based on the evaluation criteria established in the bid specifications.

- Price
- Unit Availability/Lead Time
- Features, Specifications
- Manufacturer warranty

RWRA reserves the right to reject any and all bids and to waive any irregularities in said bids, and RWRA also reserves the right to award bids based on the best interest and/or most advantageous to RWRA. Award will be made to the lowest responsive and responsible bidder meeting specifications. RWRA may or may not award all bid items. RWRA reserves the right to award a procurement contract with any one or a combination of bid items as submitted. Bidder is responsible to explicitly state if bid item pricing is dependent upon group or volume discount pricing.

### Shipping Charges

All items quoted shall be "F.O.B. Destination". No additional freight charges will be allowed. Bidder shall be responsible for loading/unloading.

### Delivery Schedule

Delivery date shall be specified on each item quoted. The vendor will be expected to fulfill the delivery as bid. The completed unit shall be delivered to RWRA at 2101 Grimes Ave, Owensboro, KY 42303. Delivery shall include offloading of unit from delivery truck onto clear, level surface. Warranty certificates, and one (1) copy of Operator's, Parts and Maintenance manuals shall be provided to RWRA at the time of delivery. Digital media is acceptable in lieu of books.

Time will be of the essence for any orders placed as a result of this Solicitation. RWRA reserves the right to cancel such orders, or any part thereof, without obligation, if delivery is not made within the time(s) specified on the Response. Deliveries are to be made during regular RWRA business hours (M-F, 7am – 3:30pm CST) unless otherwise specified in the Special Conditions.

### Indemnity Agreement

All contractors shall be required to sign an Indemnity agreement included in the bid package to be considered for this project.

### Compliance with KRS 45A.343 and KRS 45A.395

Attached are statements which must be completed by bidders. These statements are required under the listed statutes and must be completed and submitted with the bid.

### Compliance with Applicable Laws/Regulations

Successful bidder must comply with the City of Owensboro/Daviess County ordinances relating to Occupational License Fees, business Licenses, payroll and net profits taxes and any other ordinances which may apply to any particular bid package.

### Compliance with Equal Opportunity Statutes

Regional Water Resource Agency is an equal opportunity employer and does not discriminate on the basis of race, color, religion, sex, national origin, age, marital status, physical or mental disability, or any other characteristic protected by law. RWRA is also committed to employing only United States citizens and aliens who are authorized to work in the United States and complies with the Immigration Reform and Control Act of 1986. Therefore, the successful bidder must demonstrate to the satisfaction of RWRA that he also conforms to all Federal, State and Local equal opportunity statutes. Further, the contractor will reimburse RWRA for any damages incurred due to any violation of the above-mentioned statutes by the contractor while under contract.

### Safety Regulations

Unit shall meet any state or federal OSHA, NFPA, UL or DOT regulations as applicable. Unit must be provided with appropriate certificates, labels and all other applicable safety and operational testing inspection records.

### Manuals

This equipment shall be provided with an Owner's manual and a CD consisting of Service and Parts. These manuals shall be current with year model of the equipment delivered and shall accompany the delivery of the equipment.

### Standard Equipment

Unit shall contain all standard equipment listed as such in the manufacturers' latest literature unless otherwise stated within these specifications

## BASE BID SPECIFICATIONS

Detailed specifications are listed below. All bidders are expected to meet or exceed all specifications for each unit quoted. Any bidder submitting a bid which does not meet or exceed the stated specifications, is required to identify the specification which is not met, with an explanation for the exception on the "Bidders Exceptions, Conflicts and Clarifications". RWRA has an extensive knowledge and history utilizing Arc Flash rated Control Panels and has written the technical specifications to meet the specific needs of the application. Deviations from these specifications are discouraged but will be considered. RWRA reserves the right to consider any listed exception major or minor in nature and may or may not be accepted based upon RWRA system and maintenance compatibility.

These specifications describe the configuration/performance requirements for each Control Panel to be quoted:

### **(3) Arc-Flash Rated Duplex Pump Control Panels**

The proposed panels shall be Arc Flash safety isolated/divided including separate cabinet sections for 1) incoming power, 2) Hi-voltage/starters and 3) Controls; and shall provide support (at minimum) for the following listed equipment for each proposal:

#### **1) LAMPLITE PS**

- I. **Lamplite Duplex Pump Control Panel w/ Arc Flash isolated cabinets complete with the following:**
  - a. Controlling (2) 20 HP, 25.3 FL AMPS, 460 volt, 3-phase submersible sewage pumps
  - b. INCOMING POWER IS 480 VOLT 3-PHASE
  - c. NEMA RATED MAGNETIC STARTERS WITH 3 LEG OVERLOAD PROTECTION
  - d. NEMA TYPE 4X STAINLESS STEEL ENCLOSURE FOR WALL MOUNT INSTALLATION WITH PADLOCK HANDLES– BAKED ENAMEL FINISH (WHITE) NOTE: ALL ISOLATED CABINETS SHALL BE WELDED
  - e. BACK PANEL (ALL SECTIONS) AND INNER DOOR FOR THE CONTROL SECTION
  - f. ALL OPERATING CONTROLS MUST BE MOUNTED ON AND BE OPERABLE FROM METAL INNER DOOR
  - g. HAND-OFF-AUTO SWITCHES
  - h. PUMP RUN INDICATOR LIGHTS
  - i. SEAL FAIL INDICATOR LIGHTS
  - j. AMMETERS FOR EACH PUMP (INNER DOOR MOUNTED)
  - k. ALTERNATING RELAY W/LEAD PUMP SELECTOR SWITCH
  - l. FULLY ISOLATED MAIN BREAKER AND ASSOCIATED ENCLOSURE/ACCESS WITH INTERLOCK FOR HIGH VOLTAGE AREA
  - m. 100 AMP MANUAL TRANSFER SWITCH
  - n. HUBBELL HBL4100R7W GENERATOR RECEPTACLE
  - o. MOTOR, CONTROL AND POWER TRANSFORMER CIRCUIT BREAKERS
  - p. PROVIDE 3- 120 VOLT 20 AMP CIRCUITS AND TERMINAL BLOCKS FOR TELEMETRY, WELL LIGHT, AND SPARE
  - q. INCLUSION OF GFI CONVENIENCE RECEPTACLE
  - r. PUMP BREAKER TRIP AUX CONTACTS FOR EACH PUMP

- s. AUX. OVERLOAD TRIP, BREAKER TRIP, OVERTEMP, SEAL FAIL AND PUMP RUNNING DRY CONTACTS FOR TELEMTRY
- t. CONTROL CIRCUIT FUSE
- u. LEAD LAG FLOAT OPERATION IS TO BE USED FOR CONTROL
- v. SEAL FAILURE/OVERTEMPERATURE PUMP CIRCUITRY (UTILIZE PUMPSAFE NO EQUAL)
- w. CONTROL AND FAULT RELAYS AS REQUIRED
- x. TERMINAL BLOCKS AND GROUND LUGS FOR FIELD CONNECTIONS AS REQUIRED
- y. ELAPSED TIME METERS
- z. LIVE VOLTAGE LED INDICATORS MOUNTED ON EXTERIOR DOOR PANEL
- aa. PROVIDE 10 SPARE WIRED TERMINAL BLOCKS FROM HIGH VOLTAGE SECTION TO CONTROL SECTION (FOR CONTROL WIRES – EXAMPLE SCHEMATIC ATTACHED)
- bb. UL 508 LISTED
- cc. THE USE OF CORDS BETWEEN ARC-FLASH CABINET COMPARTMENTS IS NOT AN ACCEPTABLE METHODOLOGY FOR INTER-CABINET WIRING
- dd. CALL BOTH PUMPS COMMAND FROM TELEMTRY WHEN PUMP HOAS ARE IN AUTO (THIS SHOULD NOT AFFECT HAND OR OFF OPERATION- EXAMPLE SCHEMATIC ATTACHED)
- ee. DISABLE BOTH PUMPS COMMAND FROM TELEMTRY WHEN PUMP HOAS ARE IN AUTO (THIS SHOULD NOT AFFECT HAND OR OFF OPERATION- EXAMPLE SCHEMATIC ATTACHED)
- ff. INCLUDE FREIGHT

• **LAMPLITE PUMP STATION ADDIITONAL INFORMATION:**

<b>Voltage Phase</b> 3 Three Phase	<b>Voltage</b> 460	<b>Influent Flow (gpm)</b> 79
<b>Designed By</b> Quest Engineering	<b>Wet Well Data</b>	
<b>Project Number</b> 98220	<b>Construction Cost</b>	<b>Dia/Width</b> 10
<b>Force Main Dia</b> 6		<b>Rim Elevation</b> 389.53
<b>Power Provider</b> Kenergy	<b>Provider Phone</b> 270-926-4142	<b>Length</b> 0
<b>Elec Service Size</b>		<b>Bottom Elevation</b> 357.74
<b>Generator Conn</b> 4 Manual XFER Switch (CC)	<b>Generator Size</b> 30	<b>Area</b> 0
		<b>Invert Elevation</b> 365.7
		<b>High Well Float Elevation</b>

## **2) WRIGHTS ACRES PS**

- I. Wrights Acres Duplex Pump Control Panel w/ Arc Flash isolated cabinets complete with the following:**
- a. Controlling (2) 10 HP, 14.7 FL AMPS, 460 volt, 3-phase submersible sewage pumps
  - b. INCOMING POWER IS 480 VOLT 3-PHASE
  - c. NEMA RATED MAGNETIC STARTERS WITH 3 LEG OVERLOAD PROTECTION
  - d. NEMA TYPE 4X STAINLESS STEEL ENCLOSURE FOR WALL MOUNT INSTALLATION WITH PADLOCK HANDLES– BAKED ENAMEL FINISH (WHITE) NOTE: ALL ISOLATED CABINETS SHALL BE WELDED
  - e. BACK PANEL (ALL SECTIONS) AND INNER DOOR FOR THE CONTROL SECTION
  - f. ALL OPERATING CONTROLS MUST BE MOUNTED ON AND BE OPERABLE FROM METAL INNER DOOR
  - g. HAND-OFF-AUTO SWITCHES
  - h. PUMP RUN INDICATOR LIGHTS
  - i. SEAL FAIL INDICATOR LIGHTS
  - j. AMMETERS FOR EACH PUMP (INNER DOOR MOUNTED)
  - k. ALTERNATING RELAY W/LEAD PUMP SELECTOR SWITCH
  - l. FULLY ISOLATED MAIN BREAKER AND ASSOCIATED ENCLOSURE/ACCESS WITH INTERLOCK FOR HIGH VOLTAGE AREA
  - m. 100 AMP MANUAL TRANSFER SWITCH
  - n. HUBBELL HBL4100R7W GENERATOR RECEPTACLE
  - o. MOTOR, CONTROL AND POWER TRANSFORMER CIRCUIT BREAKERS
  - p. PROVIDE 3- 120 VOLT 20 AMP CIRCUITS AND TERMINAL BLOCKS FOR TELEMETRY, WELL LIGHT, AND SPARE
  - q. INCLUSION OF GFI CONVENIENCE RECEPTACLE
  - r. PUMP BREAKER TRIP AUX CONTACTS FOR EACH PUMP
  - s. AUX. OVERLOAD TRIP, BREAKER TRIP, OVERTEMP, SEAL FAIL AND PUMP RUNNING DRY CONTACTS FOR TELEMETRY
  - t. CONTROL CIRCUIT FUSE
  - u. LEAD LAG FLOAT OPERATION IS TO BE USED FOR CONTROL
  - v. SEAL FAILURE/OVERTEMPERATURE PUMP CIRCUITRY (UTILIZE MACROMATIC TCF2D100 OR EQUAL)
  - w. CONTROL AND FAULT RELAYS AS REQUIRED
  - x. TERMINAL BLOCKS AND GROUND LUGS FOR FIELD CONNECTIONS AS REQUIRED
  - y. ELAPSED TIME METERS
  - z. LIVE VOLTAGE LED INDICATORS MOUNTED ON EXTERIOR DOOR PANEL
  - aa. PROVIDE 10 SPARE WIRED TERMINAL BLOCKS FROM HIGH VOLTAGE SECTION TO CONTROL SECTION (FOR CONTROL WIRES – EXAMPLE SCHEMATIC ATTACHED)
  - bb. UL 508 LISTED
  - cc. THE USE OF CORDS BETWEEN ARC-FLASH CABINET COMPARTMENTS IS NOT AN ACCEPTABLE METHODOLOGY FOR INTER-CABINET WIRING
  - dd. CALL BOTH PUMPS COMMAND FROM TELEMETRY WHEN PUMP HOAS ARE IN AUTO (THIS SHOULD NOT AFFECT HAND OR OFF OPERATION- EXAMPLE SCHEMATIC ATTACHED)
  - ee. DISABLE BOTH PUMPS COMMAND FROM TELEMETRY WHEN PUMP HOAS ARE IN AUTO (THIS SHOULD NOT AFFECT HAND OR OFF OPERATION- EXAMPLE SCHEMATIC ATTACHED)

• **WRIGHTS ACRES PUMP STATION ADDITIONAL INFORMATION:**

<b>Voltage Phase</b> 3 Three Phase	<b>Voltage</b> 460	<b>Influent Flow (gpm)</b> 106
<b>Designed By</b> Quest Engineering		<b>Wet Well Data</b>
<b>Project Number</b> 98220	<b>Construction Cost</b>	
<b>Force Main Dia</b> 8		
<b>Power Provider</b> Kenergy	<b>Provider Phone</b> 270-926-4142	
<b>Elec Service Size</b>		
<b>Generator Conn</b> 4 Manual XFER Switch (CC)	<b>Generator Size</b> 20	

<b>Dia/Width</b> 12	<b>Rim Elevation</b> 397.6
<b>Length</b> 12	<b>Bottom Elevation</b> 370
<b>Area</b> 144	<b>Invert Elevation</b> 388.68
	<b>High Well Float Elevation</b>

**3) EASTVIEW PS**

- I. **Eastview:** (2) 15 HP, 19.9 FL AMPS, 460 volt, 3-phase Duplex Pump Control Panel w/ Arc Flash isolated cabinets complete with the following:
  - a. INCOMING POWER IS 480 VOLT 3-PHASE
  - b. NEMA RATED MAGNETIC STARTERS WITH 3 LEG OVERLOAD PROTECTION
  - c. NEMA TYPE 4X STAINLESS STEEL ENCLOSURE FOR WALL MOUNT INSTALLATION WITH PADLOCK HANDLES– BAKED ENAMEL FINISH (WHITE) NOTE: ALL ISOLATED CABINETS SHALL BE WELDED
  - d. BACK PANEL (ALL SECTIONS) AND INNER DOOR FOR THE CONTROL SECTION
  - e. ALL OPERATING CONTROLS MUST BE MOUNTED ON AND BE OPERABLE FROM METAL INNER DOOR
  - f. HAND-OFF-AUTO SWITCHES
  - g. PUMP RUN INDICATOR LIGHTS
  - h. SEAL FAIL INDICATOR LIGHTS
  - i. AMMETERS FOR EACH PUMP (INNER DOOR MOUNTED)
  - j. ALTERNATING RELAY W/LEAD PUMP SELECTOR SWITCH
  - k. FULLY ISOLATED MAIN BREAKER AND ASSOCIATED ENCLOSURE/ACCESS WITH INTERLOCK FOR HIGH VOLTAGE AREA
  - l. 100 AMP MANUAL TRANSFER SWITCH
  - m. HUBBELL HBL4100R7W GENERATOR RECEPTACLE
  - n. MOTOR, CONTROL AND POWER TRANSFORMER CIRCUIT BREAKERS
  - o. PROVIDE 3- 120 VOLT 20 AMP CIRCUITS AND TERMINAL BLOCKS FOR TELEMTRY, WELL LIGHT, AND SPARE



- p. INCLUSION OF GFI CONVENIENCE RECEPTACLE
- q. PUMP BREAKER TRIP AUX CONTACTS FOR EACH PUMP
- r. AUX. OVERLOAD TRIP, BREAKER TRIP, OVERTEMP, SEAL FAIL AND PUMP RUNNING DRY CONTACTS FOR TELEMTRY
- s. CONTROL CIRCUIT FUSE
- t. LEAD LAG FLOAT OPERATION IS TO BE USED FOR CONTROL
- u. SEAL FAILURE/OVERTEMPERATURE PUMP CIRCUITRY (UTILIZE PUMPSAFE NO EQUAL)
- v. CONTROL AND FAULT RELAYS AS REQUIRED
- w. TERMINAL BLOCKS AND GROUND LUGS FOR FIELD CONNECTIONS AS REQUIRED
- x. ELAPSED TIME METERS
- y. LIVE VOLTAGE LED INDICATORS MOUNTED ON EXTERIOR DOOR PANEL
- z. PROVIDE 10 SPARE WIRED TERMINAL BLOCKS FROM HIGH VOLTAGE SECTION TO CONTROL SECTION (FOR CONTROL WIRES – EXAMPLE SCHEMATIC ATTACHED)
- aa. UL 508 LISTED
- bb. THE USE OF CORDS BETWEEN ARC-FLASH CABINET COMPARTMENTS IS NOT AN ACCEPTABLE METHODOLOGY FOR INTER-CABINET WIRING
- cc. CALL BOTH PUMPS COMMAND FROM TELEMTRY WHEN PUMP HOAS ARE IN AUTO (THIS SHOULD NOT AFFECT HAND OR OFF OPERATION- EXAMPLE SCHEMATIC ATTACHED)
- dd. DISABLE BOTH PUMPS COMMAND FROM TELEMTRY WHEN PUMP HOAS ARE IN AUTO (THIS SHOULD NOT AFFECT HAND OR OFF OPERATION- EXAMPLE SCHEMATIC ATTACHED)
- ee. INCLUDE FREIGHT

• **EASTVIEW PUMP STATION ADDITIONAL INFORMATION:**

<b>Voltage Phase</b>	<b>Voltage</b>	<b>Influent Flow (gpm)</b>
3 Three Phase	460	150
<b>Designed By</b> Quest Engineering		
<b>Project Number</b>	<b>Construction Cost</b>	<b>Wet Well Data</b>
98220		<b>Dia/Width</b> 14
<b>Force Main Dia</b>		<b>Rim Elevation</b> 393.5
10		<b>Length</b> 0
<b>Power Provider</b>	<b>Provider Phone</b>	<b>Bottom Elevation</b> 370.5
Kenergy	270-926-4142	<b>Area</b> 0
<b>Elec Service Size</b>		<b>Invert Elevation</b> 377.92
		<b>High Well Float Elevation</b>
<b>Generator Conn</b>	<b>Generator Size</b>	
4 Manual XFER Switch (CC)	30	

**SAMPLE SCHEMATICS:**

- **CALL BOTH PUMPS AND DISABLE BOTH PUMPS AUTO COMMAND EXAMPLE**

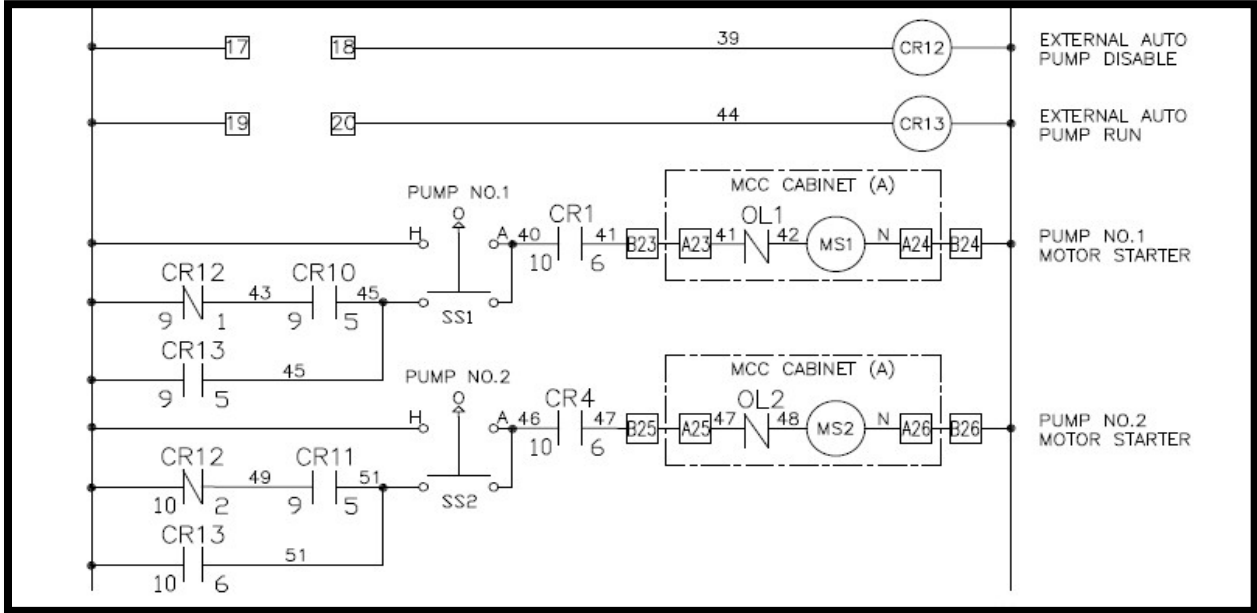

- **10 SPARE CONTROL WIRES EXAMPLE**

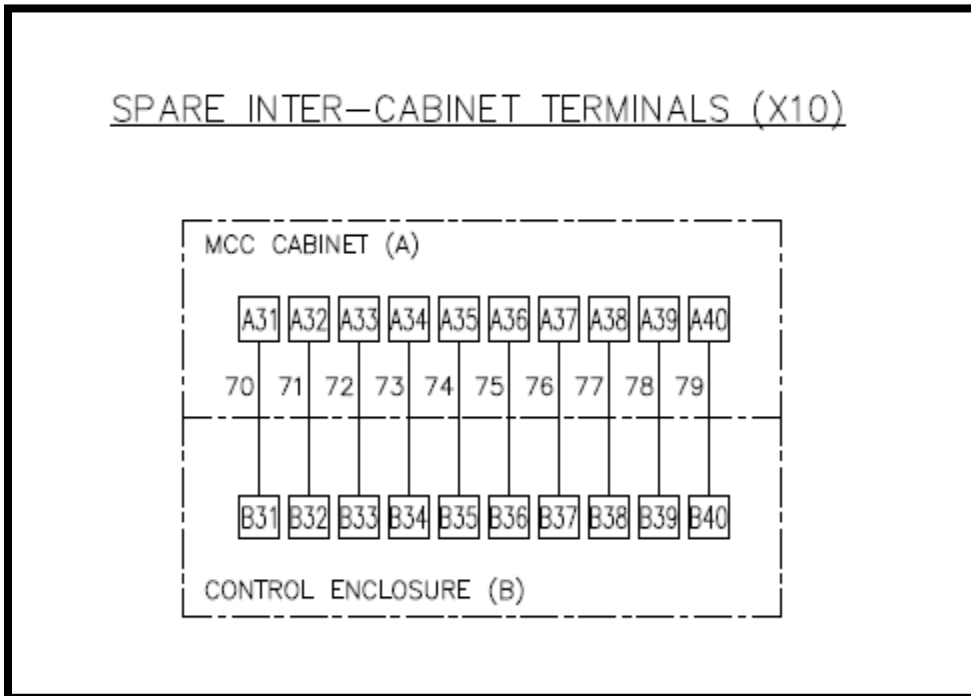

### Additional Information

Requests for additional information or clarifications of bid specifications should be directed to Tonya Smith, Purchasing Manager, Telephone (270) 687-8440, or by email at [bids@rwra.org](mailto:bids@rwra.org) in accordance with the Instructions to Bidders listed herein. Bidders are required to acknowledge receipt of all addenda on the quotation sheet submitted with the bid. Addenda will be emailed to all prospective bidders of record and posted on <https://rwra.org/contracting-with-rwra/> website.

Any bidder who receives this bid other than directly from the RWRA shall notify the RWRA that they have received the bid. This will allow the RWRA to notify all bidders of any addenda.

## 2025-29 Quotation Sheet

Please quote on the items listed below. RWRA reserves the right to reject all or any part of offer. All bidders are responsible for reading and complying with the attached specifications.

Bid Item #	Panel Application	Panel Manufacturer Name	Unit Price w/ All Accessories (\$)	Freight Cost (\$)	Total Item Cost Delivered (\$)	Production and Delivery Schedule After Receipt of Order (Wks)	Warranty Labor (Yrs)	Warranty Parts (Yrs)
<b>BASE BID:</b>								
1	<u>Lamplite</u> Duplex Pump Control Panel		\$	\$	\$		Wks	/
2	<u>Wrights Acres</u> Duplex Pump Control Panel		\$	\$	\$		Wks	/
3	<u>Eastview</u> Duplex Pump Control Panel		\$	\$	\$		Wks	/
					<b>Total Bid - 3 Panels:</b>	\$		